

NANO

Quick Start Guide

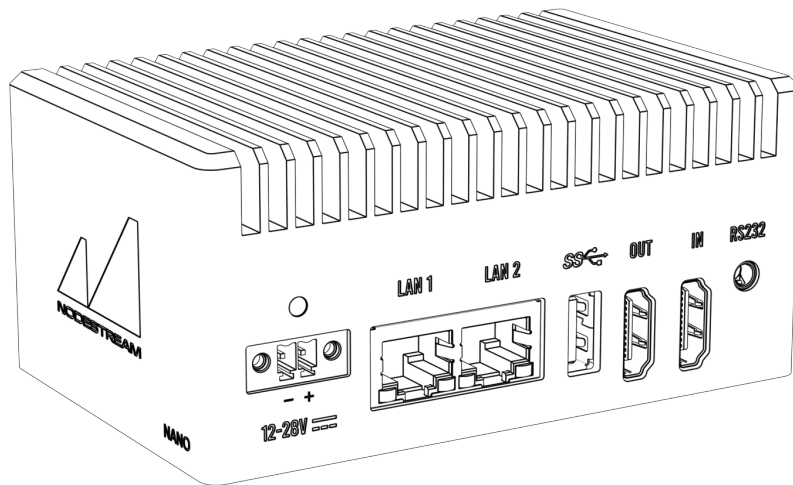



Welcome to Nodestream Nano

Please read these instructions carefully before using this product, and save this quick start guide for future reference. See the User Manual for full details via the QR code on the back page.

Features

- 16 x video streams (Nodestream Live)
- 4 x video streams (Nodestream X)
- Audio and data channels (Nodestream X)
- Low power consumption
- Native HDMI input
- Native RS232 serial input
- Low power consumption
- Wide input voltage range

In the Box

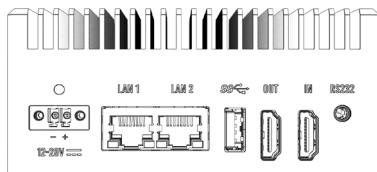

Nodestream Nano

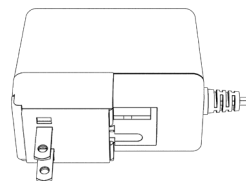

AC/DC PSU



Surface Mount



DIN Mount

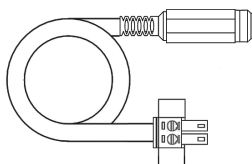

Power Cable
(2pin to 2.5mm Barrel)

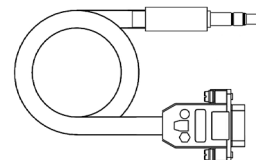

Serial Cable
(3.5mm to DB9)



Connections / UI

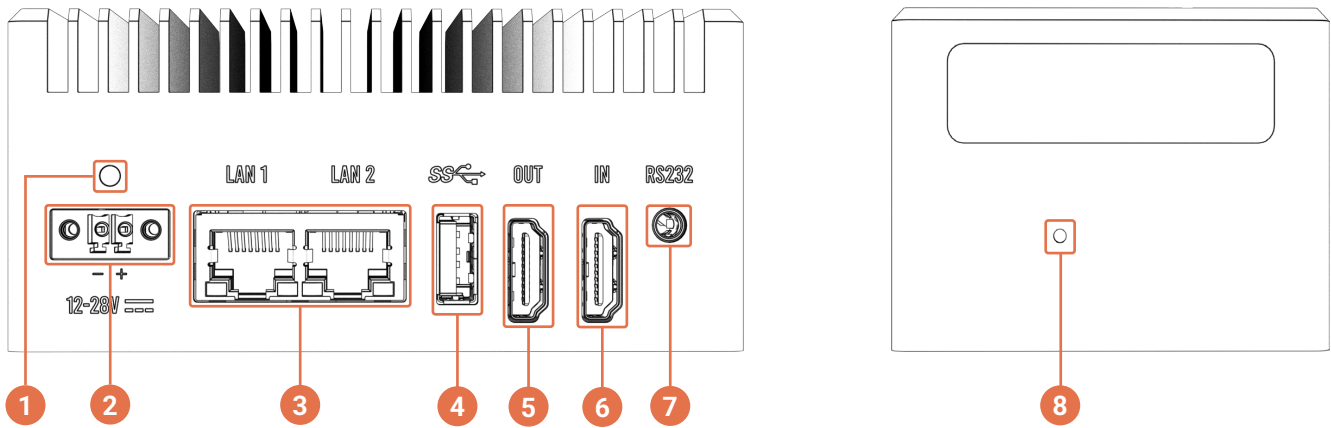

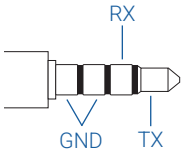
- 1 Status LED**
RGB LED to indicate system status
BLUE - System start **GREEN** - Solid (streaming), Flash (idle) **RED** - Network/server issue
- 2 Power Input**
12-28VDC
- 3 LAN 1**
Primary interface for connection to your WAN
LAN 2
Secondary interface for connection to networks sources that differ to the primary
- 4 USB A 3.0**
Connection of peripherals such as keyboard/mouse, camera
- 5 HDMI OUT**
Display output
- 6 HDMI IN**
Video source input
- 7 RS232 Serial**
3.5mm TRRS (/dev/ttyTHS0)

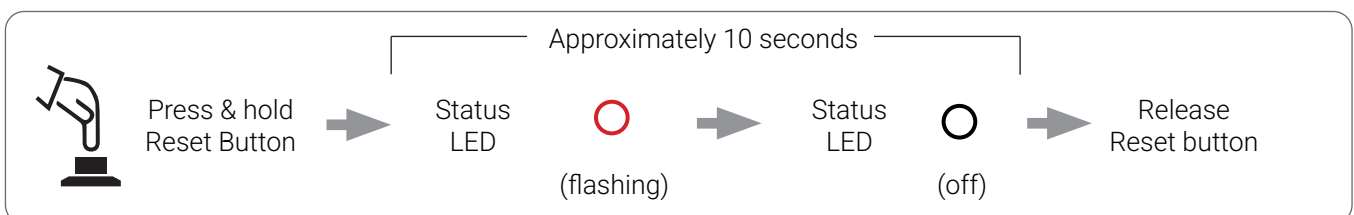
- 8 Reset Button**
Restart Device - Press 2 seconds & release
Factory reset device



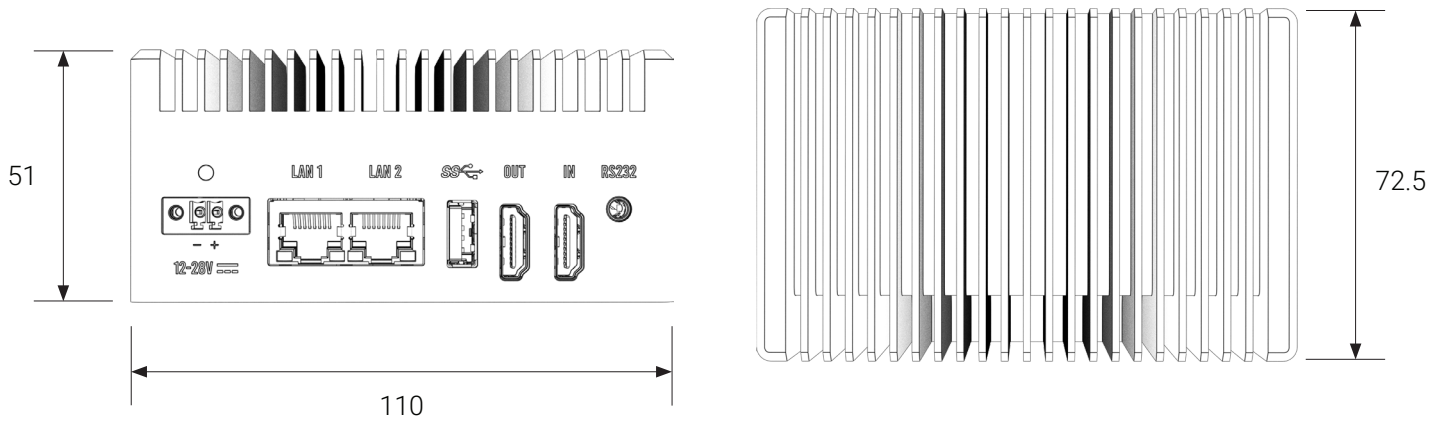

Dimensions



Installation

Freestanding or mounted using either the supplied DIN or surface mount adapter.

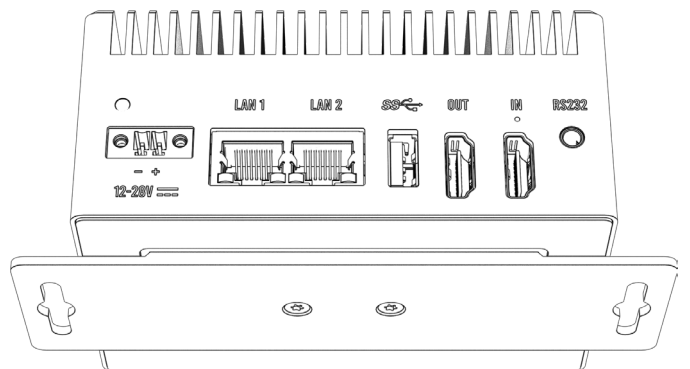
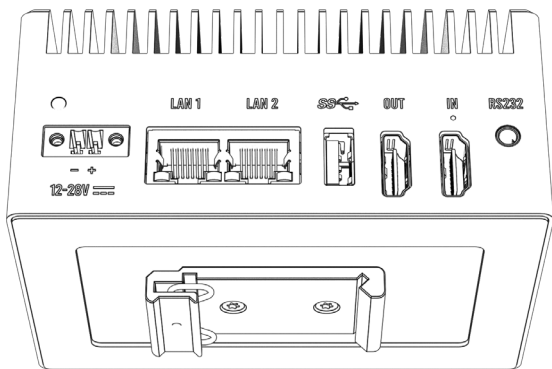

- Ensure adequate space around heat sink for cooling
- For ambient temperatures exceeding 50°C, 0.5m/s of airflow across the heatsink is required



Web Interface

1. Access the Web Interface

Via a computer on the same network

DHCP Enabled Network

From the web browser of a PC connected to the same LAN, navigate to:
device serial.local - e.g. au2518nsnx2a012.local, or the IP address of the device

Non DHCP Enabled Network

Configure the IPv4 network settings of a PC connected to the same LAN to:

IP	192.168.100.102
Subnet	255.255.255.252
Gateway	192.168.100.100

From a web browser, navigate to: 192.168.100.101



- Device will “fall back” to a static IP address when not connected to a DHCP enabled network - approximately 30 seconds after boot
- Due to the possibility of conflicting IP addresses, only 1 device can be configured at a time. Once configured, the device can remain connected

On the device

Press **alt+F1** on a connected keyboard

2. Login in - username & password = admin
3. Configure your network
4. Select device mode and configure your server on the “System” page



Once registered to a server, your device will need to be added to a group



Add your device to your Organization via the web portal



- Refer to the device User Manual for more information
- Add and manage inputs via you Nodestream X control application or NSLive portal



- Your WAN **MUST** be connected to LAN 1 of your device
- Nodestream devices require specific firewall settings to be in place. Refer to the User Manual for further information



User Resources



Contact and Support
support@harvest-tech.com.au

Troubleshooting

Issue	Cause	Resolution
Device not powering	DC not connected Incorrect polarity Faulty or incompatible supply	Confirm supply is connected and turned on Confirm power input cable is connected correctly Test with alternative supply Ensure supply voltage meets required specifications, refer User Manual
Nodestream X "Server Connection Error" Nodestream Live "Could not resolve hostname" Status LED RED	Network not connected Network settings incorrect Firewall blocking comms Not registered to server	Check Ethernet cable is connected Check network settings, contact your Network administrator to diagnose network Ensure Firewall settings correct, see User Manual Register device on your Nodestream server
No video input	Sources not connected, powered on or correctly configured	Confirm sources connected and powered on, refer User Manual for configuration
Forgot login or network details	N/A	Factory reset to defaults (refer "Connections / UI" on page 3)

EU | REP | Harvest Technology Europe (colm.mulcahy@harvest-tech-europe.com ; +353 87 8126761)
Suite 4, Eden Gate Business Centre, Delgany, A63 WY44 Wicklow, Ireland

UK | REP | Dallas Allardice (dallas.allardice@harvest-tech.com.au ; +44 7921567416)
Overton Lodge, Methlick, Ellon, UK, AB41 7HT



Harvest Technology Pty Ltd
7 Turner Ave, Technology Park
Bentley WA 6102, Australia
harvest.technology

All rights reserved. This document is the property of Harvest Technology Pty Ltd. No part of this publication may be reproduced, stored in a retrieval system or transmitted in any form or by any means, electronic, photocopy, recording or otherwise without the written consent of the CEO of Harvest Technology Pty Ltd.